

### Three-phase capacitors: 580 V, 50 Hz, IP 20, MKP

Typ Type	Výkon Power $Q_N$ [kvar]	Kapacita Capacitance $C_N$ [ $\mu$ F]	Proud Current $I_N$ [A]	Váha Weight [kg]	Rozměry Dimensions $\varnothing D \times H$ [mm]
CSADG 1-0,58/25	25,0	3 x 78,9	3 x 24,9	2,1	110 x 245

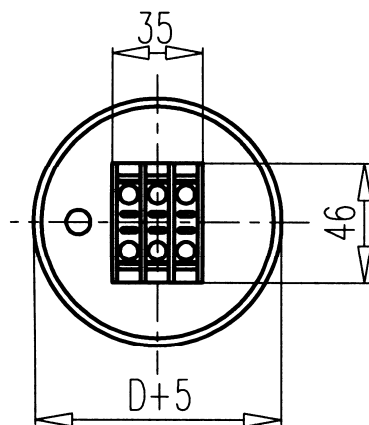
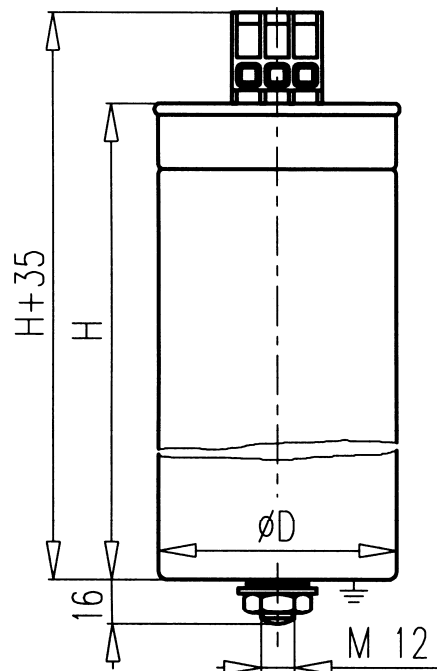

#### Technická data/ Technical data:

Teplotní kategorie/ Temperature category: -25/D

Vybíjecí odpory/ Discharge resistors: 50 V/ 1 min

Izolační hladina/ Insulation level: 3,2 / - kV

Konstrukce/ Design: SH - suché provedení  $N_2$  / SH - dry type  $N_2$ , non PCB

Normal Standard: IEC 60831/96

Kreslil	Michalovičová	Dne	30.8.2007	Změna	
Schválil	Falta Vladimír	Dne			



Název:

**TECHNICAL SPECIFICATION**  
580 V, 50 Hz, 3-F, IP20

**3J 2266 A**