

Three-phase capacitors: 400 V, 50 Hz, IP 20, MKP

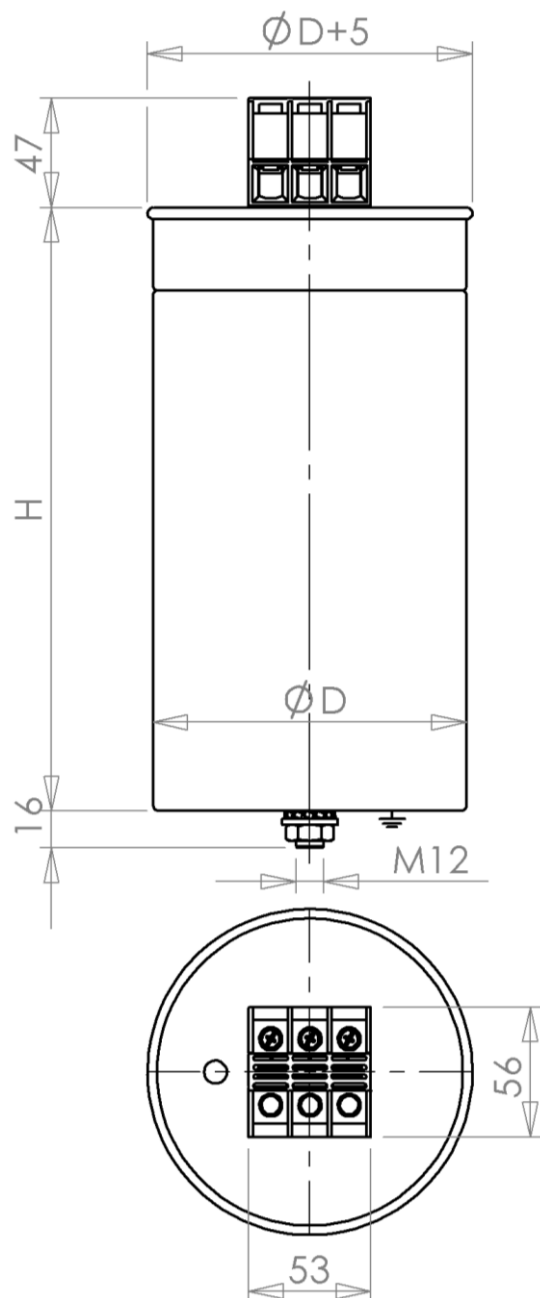

Typ/ Type	Výkon/ Power Q_N [kvar]	Kapacita/ Capacitance C_N [μ F]	Proud/ Current I_N [A]	Rozměry/ Dimensions $\varnothing D \times H$ [mm]	Váha/ Weight [kg]
CSADG 3-0,4/33,3	33,3	3 x 221	3 x 48,1	136 x 261	3,1
CSADG 3-0,4/37,5	37,5	3 x 249	3 x 54,2		3,3
CSADG 3-0,4/40	40,0	3 x 265	3 x 57,8		3,4

Technická data/ Technical data:

Teplotní kategorie/ Temperature category: -40/D

Vybíjecí odpory/ Discharge resistors: 75 V/ 3 min

Izolační hladina/ Insulation level: 3 / 12 kV

Konstrukce/ Design: SH - suché provedení/ SH – dry soft N_2 , non PCB

Normal/ Standard: IEC 60831-1:2002

Kreslil	Michalovičová	Dne	26.4.2011	Změna	
Schválil	Falta Vl.	Dne	28.4.2011		
				Název: TECHNICAL SPECIFICATION 400 V, 50 Hz, 3-F, IP20	
				3J 2702A	